



Bulletin MSG11-5715-690/UK

Operating instructions Series D1VW*EE

Design series 93

II 2 G c T4 Gb

-20 °C < T_a < +60 °C



Directional Control Valve



Parker Hannifin

Manufacturing Germany GmbH & Co. KG

Industrial Systems Division Europe

Gutenbergstr. 38

41564 Kaarst, Germany

E-mail: isde.kaarst.support@support.parker.com

Copyright © 2022, Parker Hannifin Corp.



WARNING — USER RESPONSIBILITY

FAILURE OR IMPROPER SELECTION OR IMPROPER USE OF THE PRODUCTS DESCRIBED HEREIN OR RELATED ITEMS CAN CAUSE DEATH, PERSONAL INJURY AND PROPERTY DAMAGE.

This document and other information from Parker-Hannifin Corporation, its subsidiaries and authorized distributors provide product or system options for further investigation by users having technical expertise.

The user, through its own analysis and testing, is solely responsible for making the final selection of the system and components and assuring that all performance, endurance, maintenance, safety and warning requirements of the application are met. The user must analyze all aspects of the application, follow applicable industry standards, and follow the information concerning the product in the current product catalog and in any other materials provided from Parker or its subsidiaries or authorized distributors.

To the extent that Parker or its subsidiaries or authorized distributors provide component or system options based upon data or specifications provided by the user, the user is responsible for determining that such data and specifications are suitable and sufficient for all applications and reasonably foreseeable uses of the components or systems.

Contents	Page
0. EC declaration of conformity	4
1. Introduction	6
Technical data	6
Ordering code	7
Characteristic curves	8
Dimensions	10
Name plate	11
2. Safety instructions	11
Symbols	11
Marking, name plates	11
Work on the valve	11
3. Important information	12
Correct use	12
Common instructions	12
Liability	12
Storage	12
4. Installation	12
Scope of delivery	12
Installation	12
Electrical connection	13
Operation limits	13
Pressure fluids	13
5. Operating instructions	14
Air bleeding of hydraulic system	14
Filter	14
Flushing	14
6. Maintenance	14
Replacement of a coil	14
7. Troubleshooting	16
A1 Extract from standards/directives	17
A2 User guide – solenoid	18
A3 Type-examination certificate – solenoid	22
A4 Declaration of conformity - solenoid	36
A5 Mounting instruction cable gland	37

0. EC declaration of conformity

EG-Konformitätserklärung / EC-Declaration of Conformity
2014/34/EU (ATEX)



Parker Hannifin Manufacturing Germany GmbH & Co. KG
Hydraulic Controls Division Europe
Gutenbergstrasse 38
41564 Kaarst, Germany

Parker Hannifin erklärt, dass die nachstehenden Produkte auf Seite 2 explosionsgeschützt ausgeführte Geräte im Sinne des Artikels 1 (3) der Richtlinie 2014/34/EU sind und die grundlegenden Sicherheits- und Gesundheitsanforderungen gemäß Anhang II dieser Richtlinie erfüllen.

Parker Hannifin declares, that series on page 2 are explosion-proofed components according to article 1 (3) of directive 2014/34/EU and they fulfill the basic health and safety requirements specified in Annex II of this directive.

Folgende harmonisierte Normen wurden angewandt – weitere Hinweise zur Konformitätsaussage enthält die technische Dokumentation:

Below harmonised standards used – the technical documentation covers additional information regarding declaration of conformity:

- | | |
|------------------|---|
| EN 1127-1:2011 | Explosionsfähige Atmosphären – Explosionsschutz
Teil 1: Grundlagen und Methodik
Explosive atmospheres - Explosion prevention and protection - Part 1: Basic concepts and methodology |
| EN ISO 4413:2010 | Fluidtechnik – Allgemeine Regeln und sicherheitstechnische Anforderungen an Hydraulikanlagen und deren Bauteile
Hydraulic fluid power - General rules and safety requirements for systems and their components |
| EN 13463-1:2009 | Nicht-elektrische Geräte für den Einsatz in explosionsgefährdeten Bereichen
Teil 1: Grundlagen und Anforderungen
Non-electrical equipment for use in potentially explosive atmospheres - Part 1: Basic method and requirements |
| EN 13463-5:2011 | Nicht-elektrische Geräte für den Einsatz in explosionsgefährdeten Bereichen
Teil 5: Schutz durch konstruktive Sicherheit "c"
Non-electrical equipment intended for use in potentially explosive atmospheres - Part 5: Protection by constructional safety "c" |

Die Geräte erfüllen die Anforderungen entsprechend der Kategorie / Angaben zur Kennzeichnung (Typenschild):
The components fulfill the requirements of category / identification marking (on nameplate):



Der korrekte Gebrauch der Geräte bei Installation und Betrieb wird vorausgesetzt. Details zum korrekten Gebrauch (einschließlich Explosionsschutz) sind in der Betriebsanleitung hinterlegt.
It is mandatory, that the installation and the operation of the components are according to their designated usage. Information to the designated use are given in installation manual and product documentation.

Die beschriebenen Produkte sind in Übereinstimmung mit den einschlägigen EU-Harmonisierungsvorschriften: Richtlinie 94/9/EG (bis 19. April 2016) und Richtlinie 2014/34/EU (ab 20. April 2016).
The products of the declaration described are in conformity with the relevant Union harmonisation legislation: Directive 94/9/EC (until 19 April 2016) and Directive 2014/34/EU (from 20 April 2016).

Ort, Datum / Place, date:

Kaarst, 20.04.2016

Unterschrift / Signature:

Angaben zum Unterzeichner / Name and position:

Hansgeorg Kolvenbach / General Manager

2014-34-eu_Wege-G-60_20-04-16_Fu

EG-Konformitätserklärung / EC-Declaration of Conformity 2014/34/EU (ATEX)

Nachstehend alle Produkte, die den Anforderungen der Richtlinie entsprechen:
Products that correspond fulfill to the requirements of directive:

1. **Vorgesteuerte Proportional-Wegeventile / pilot operated proportional DC valves**
 - D31FB*EE-XG371
 - D41FB*EE-XG371
 - D91FB*EE-XG371
 - D111FB*EE-XG371
2. **Direktgesteuerte Proportional-Wegeventile / direct operated proportional DC valves**
 - D1FB*0EE-XG371
 - D1FB*3EE-XG371
3. **Vorgesteuerte Wegeventile / pilot operated DC valves**
 - D31DW*EE
 - D31NW*EE
 - D41VW*EE
 - D81/91VW*EE
 - D111VW*EE
4. **Direktgesteuerte Wegeventile / direct operated DC valves**
 - D1VW*EE
5. **Proportional Druckreduzierventile / proportional pressure reducing valves**
 - D1FV*EE-XG371

2014-34-eu_Wege-G-60_20-04-16_Fu

Operating Instructions

1. Introduction

The D1VW with explosion proof solenoids is based on the standard D1VW series. The specific solenoid design allows the usage in hazardous environments.

The explosion proof class is

CE  II 2 G
Ex e mb IIC T4 Gb

for use in zone 1 and 2 (according to ATEX).

Additionally the solenoids are IECEx compliant.

All explosion proof solenoids are DC design. The valves for AC operate with integrated rectifier.

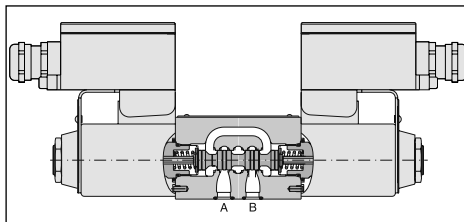
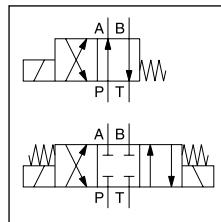
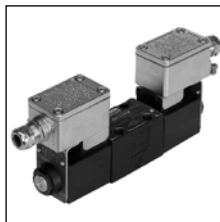

Technical data

General	
Design	Directional spool valve
Actuation	Solenoid
Size	DIN NG06 / CETOP 03 / NFPA D03
Mounting interface	DIN 24340 A6 / ISO 4401 / CETOP RP 121-H / NFPA D03
Mounting position	unrestricted, preferably horizontal
Ambient temperature	[°C] -20...+60
MTTF _D	[years] 150
Weight	[kg] 1.8 (1 solenoid), 2.7 (2 solenoids)
Hydraulic	
Max. operating pressure	[bar] P, A B: 350; T: 210
Fluid	Hydraulic oil according to DIN 51524
Fluid temperature	[°C] -20 ... +60
Viscosity permitted	[cSt] / [mm ² /s] 2.8...400
Viscosity recommended	[cSt] / [mm ² /s] 30...80
Filtration	ISO 4406 (1999); 18/16/13
Flow max.	[l/min] 60 (see shift limits)
Leakage at 50 bar	[ml/min] Up to 10 per flow path, depending on spool
Static / Dynamic	
Step response at 95 %	[ms] Energized: 32 (DC), 40 (AC) De-energized: 40 (DC), 75 (AC)
Electrical characteristics	
Duty ratio	100 % ED; CAUTION: coil temperature up to 135 °C possible
Max. switching frequency	[1/h] 15000 (DC), 7200 (AC)
Protection class	CE  II 2 G , Ex e mb IIC T4 Gb, IP66 (plugged and mounted correctly)
	Code
Supply voltage / ripple	[V] J 24 V = N 230/50 Hz P 110/50 Hz
Tolerance supply voltage	[%] ±10 ±10 ±10
Current consumption	[A] 1.0 0.12 0.25
Power consumption	[W] 24 24 24
Solenoid connection	Box with M20x1.5 entry for cable glands. Solenoid identification as per ISO 9461.
Wiring min.	[mm ²] 3 x 1.5 recommended
Wiring length max.	[m] 50 recommended

With electrical connections the protective conductor (PE \downarrow) must be connected according to the relevant regulations.

Operating Instructions

Directional Control Valve Series D1VW Explosion Proof

Ordering code

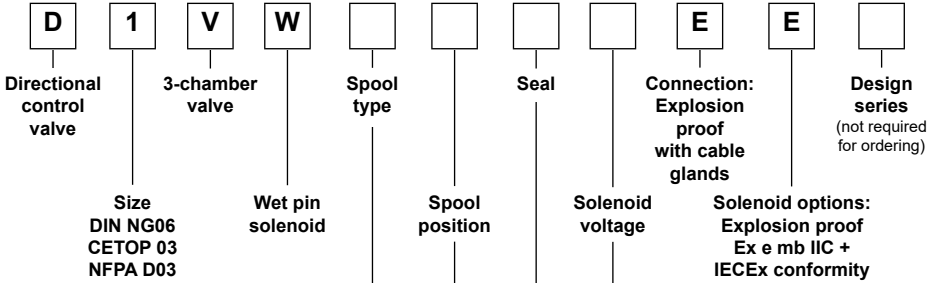

3 position spools	
Code	Spool type
	a 0 b
001	
002	
003	
004	
005	
006	
007	
008 1)	
009 1)	
010	
011	
014	
015	
016	
021	
022	
081	
082	
102	

2 position spools	
Code	Spool type
	a b
020	
026	
030	
101	

Code	Voltage
J	24 V=
P	110 V/50 Hz
N	230 V/50 Hz

Code	Seal
N	NBR
V	FPM

3 position spools		
Code	all 3 position spools	
C		3 positions. Spring offset in position "0". Operated in position "a" or "b".
	Standard	Spool type 008, 009
E	 Operated in position "a".	 Operated in position "b". 2 positions. Spring offset in position "0".
K	 Operated in position "b".	 Operated in position "a". 2 positions. Spring offset in position "0".

2 position spools		
Code	Spool position	
B		2 positions. Spring offset in position "b". Operated in position "a".
D		2 positions. Operated in position "a" or "b". No center or offset position.
H		2 positions. Spring offset in position "a". Operated in position "b".

1) Consider specific spool position

Further spool types, styles and combinations on request.

Operating Instructions

Directional Control Valve Series D1VW Explosion Proof

The flow curve diagram shows the flow versus pressure drop curves for all spool types. The relevant curve number for each spool type, operating position and flow direction is given in the table below.

Spool	Position "b"			Position "a"			Position "0"				
	P-A	B-T	P-B	P-B	A-T	P-A	P-A	P-B	A-T	B-T	P-T
001	2	2		2	2						
002	1	4		1	4		1	1	5	5	2
003	3	4		3	6				7		
004	2	3		2	3				7	7	
005	2	2		2	2		12				
006	1	4		1	4		7	7			
007	3	2		2	2			3		2	7
010	3			3							
011	2	2		2	2				14	14	
014	3	2		2	2		3		2		7
015	3	6		3	4					7	
016	2	2		2	2			12			
020B	4	4		2	3						
026B	4			4							
030B	2	3		1	2						
081	13	13		13	13						
082	13	13		13	13				1)	1)	
101B	11	10		10	9						
102	1	4		1	4		5	5	8	8	6
	P-B	A-T		P-A	B-T		P-A	P-B	A-T	B-T	P-T
008	4	5		4	5						9
009	5	5		6	7						7

Spool	Position "b"			Position "a"		
	P-A	P-B	A-B	P-B	A-T	
021	2	4		4	2	
	P-A	B-T		P-A	P-B	A-B
022	6	2		5	2	

Flow curve diagram

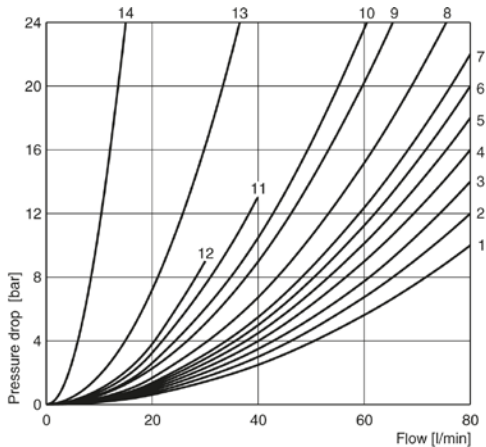

All characteristic curves measured with HLP46 at 50 °C.

1) Only for pressure compensation, no high flow possible.

Operating Instructions

Shift limits

The diagram below specifies the shift limits for valves with AC and DC solenoids. The specifications apply to a viscosity of 40 mm²/s and balanced flow conditions. The shift limits can be considerably lower at unbalanced flow conditions. To avoid flow rates beyond the shift limits, a plug-in orifice can be inserted in the P-port.

Shift limit diagram with DC solenoid

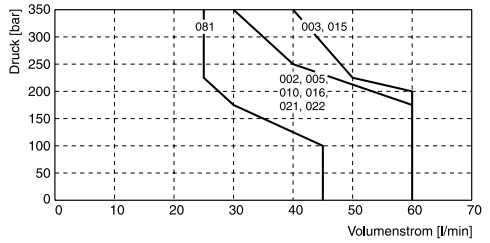
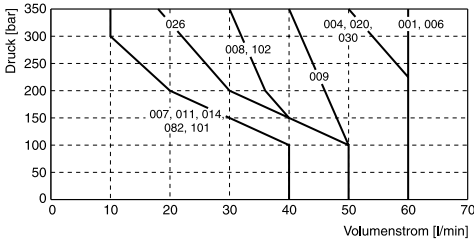

Measured with HLP46 at 50 °C, 90 % U_{nom} and warm solenoids

Shift limit diagram with AC solenoid

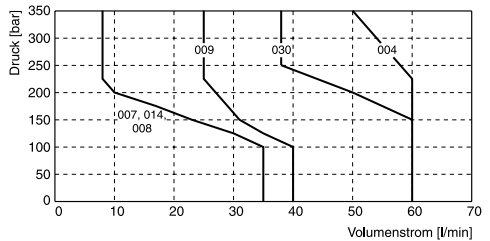
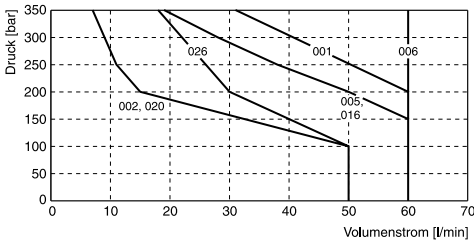

Measured with HLP46 at 50 °C, 95 % U_{nom} and warm solenoids

Operating Instructions

Dimensions

B, E -style

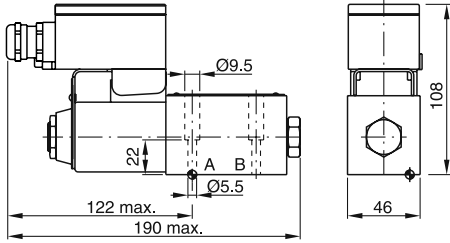



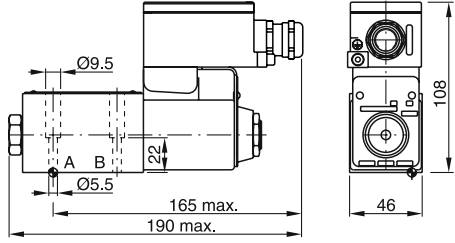

H, K -style

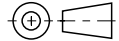
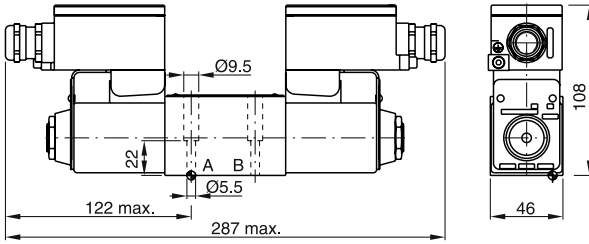

C, D -style

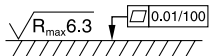

Surface finish	 Kit	 Kit	 Kit	 Kit NBR
	BK375	4x M5x30 ISO 4762-12.9	7.6 Nm ±15 %	NBR: SK-D1VW-N-91 FPM: SK-D1VW-V-91

Operating Instructions

Name plate

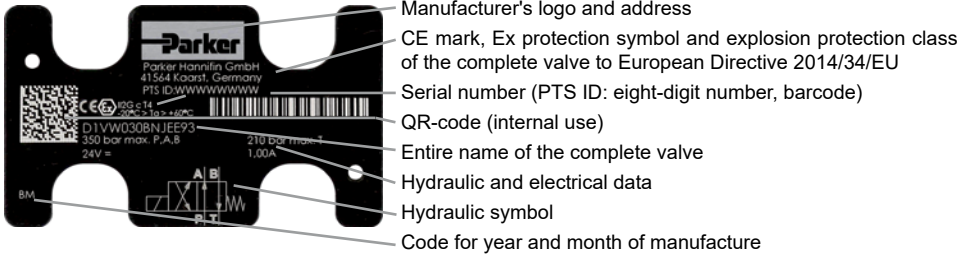

2. Safety instructions

Read the operating instructions thoroughly before installation, commissioning, maintenance, repair and storage, and observe them. Failure to observe the operating instructions may result in damage to the valve or the parts of the system connected to it.

In particular, in the case of explosive atmospheres, any failure to observe the operating instructions may result in an explosion.

The system operator must make these operating instructions visible and easily accessible to operating and maintenance personnel.

Compliance with applicable standards/legal requirements must be enforced. This particularly applies to plant safety and environmental protection.

A list of such standards, etc. appears in the annex by way of example.

Before starting commissioning, installation, maintenance and repair work, the hydraulic system must be depressurised and power must be disconnected from the electrical installation.

In addition, the electrical installation must be secured so that power cannot be restored unexpectedly.





The valve may become hot during operation. To avoid risk of burns, do not touch the valve surface.

The system operator must monitor the temperature and cool the oil if necessary in order to the keep within the maximum temperatures set out in these operating instructions (see technical data). In this connection, observe the relevant directions in the operating instructions of the supplier (solenoid system).

Any leaks occurring at the valve must be rectified immediately.

Symbols

These instructions use symbols that must be noted according to their importance:

-  Notes relating to the warranty
-  Notes relating to potential damage to the valve or connected system components
-  Notes relating to potential hazards
-  Useful additional information

Marking, name plates

Information attached directly to the valve such as circuit plans and name plates must be observed and kept in a legible state.

Work on the valve

Work relating to the installation, commissioning, maintenance and repair of the valve may only be carried out by qualified persons. Qualified persons are defined as persons who, on the basis of education, experience and instruction, have sufficient knowledge of applicable requirements and accepted rules of the technology.

Throughout any installation, commissioning, maintenance and repair work, it is the responsibility of the operator to ensure that there is no risk of explosion.

Before starting such work, the operator has to ensure that tools and equipment are only used if they do not damage the valve and they do not leave behind residues that are inflammable.

In addition, clean the valve before starting such work, in particular removing dust, liquids and other deposits. Cleaning should be done using a lint-free cloth.

Tools may not be used if they might cause a static charge on use.

Operating Instructions

3. Important information

Correct use



These operating instructions apply to DC valves of series D1VW*EE, which are intended solely for use in mineral oil based hydraulic systems (DIN 51524).

Compliance with the operating instructions must be ensured.

It is the responsibility of the operator to ensure that the information in the technical data is followed.

Any different or modified use is not classed as correct use.

The manufacturer's warranty will not cover any resulting damage.

Common instructions

We reserve the right to make technical changes as a result of further development of the product described in these operating instructions. Figures and drawings in these instructions are simplified depictions. As a result of further development, improvements and changes to the product, it is possible that the figures are not fully consistent with the described valve.

The technical details and dimensions are non-binding. They may not form the basis of any claims. Copyright reserved.

Liability

The manufacturer cannot accept liability for loss or damage resulting from the following faults:

- incorrect installation
- unqualified operation
- inadequate maintenance
- use beyond specification



Do not dismantle the valve. If you suspect a defect, return the valve to Parker.

Storage

If the valve needs to be temporarily stored, it must be protected from dirt, the weather, and mechanical damage. Each valve is tested with hydraulic oil in the factory, so that the internal components are protected from corrosion. However, this protection can only be guaranteed under the following conditions:

Storage time	Storage requirements
12 months	constant air humidity < 60 % constant temperature < 25 °C
6 months	varying air humidity, varying temperature < 35 °C



Storage outside or in maritime or tropical climates leads to corrosion and may make the valve unusable.

4. Installation

Scope of delivery

As soon as you receive the valve you should check if the package has the specified contents. In particular, check whether the type of protection indicated on the valve is as described in these operating instructions.

The scope of delivery includes:

- Valve
- Operating instructions (including operating instructions of the valve as well as of the solenoid and the declarations of conformity of the manufactures)



As soon as you receive the shipment, please check for any obvious signs of damage caused by careless transport. Document the transport damage and immediately notify the carrier, the insurance company and the supplier.

Installation

- Compare the valve type as stated on the Name plate with the parts list/circuit diagram.
- The valve can be installed in any position, either fixed or movable.



Check the fixing surface and the cavity for the valve. Permitted values: unevenness 0.01 mm/100 mm, roughness $R_{max} = 6.3 \mu m$. Keep the valve mounting surface and the area clean.

- Before installation, remove the protective cover from the valve ports.
- Check that the valve ports and the O-rings are in the correct position.
- Use fastening screws as indicated in the catalogue, property class 12.9 to ISO 4762.



Parker can supply the correct screw sets, see the catalogue for order numbers.

- Tighten the screws diagonally, torque as specified in the catalogue.
- Any deficiencies of the valve mounting surface may result in operating disruptions. Faulty fixing and incorrect screw tightening torques may lead to the sudden escape of hydraulic fluid at the ports.

The valve must be connected to the equipotential bonding system of the hydraulic system.

Size 6, mounting pattern ISO 4401-03-03-0-05

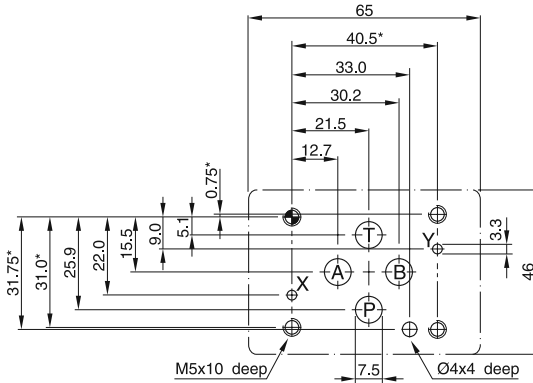

Electrical connection

Observe operating instructions D14-2128D3-* and K14-2074D3-* in the annex.

Operation limits

The valve may only be deployed with the specified limits of use. The relevant details can be found in the catalogue sheet under "Technical data" and "Characteristic curves".



Observe the ambient conditions. Unauthorised temperatures, shocks, the effects of aggressive chemicals, radiation, unauthorised electromagnetic emissions may result in disruptions and failures. Observe the limits of operation set out in "Technical data".



Excessive temperatures may cause the solenoid to overheat, creating the risk of explosion. To permit adequate heat dissipation, the solenoid coil should not be painted.

Pressure fluids

The following rules apply for the operation with various pressure fluids:



This information serves for orientation and does not substitute user tests among the particular operating conditions. Particularly no liability for media compatibility may be derived out of it.

Mineral oil: usable without restriction.

For operation with the following pressure fluids please consult Parker:

HFA	oil-in-water emulsion
HFB	water-in-oil emulsion
HFC	aqueous solution (glycols)
HFD	anhydrous fluids (Phosphor-Ester)



For detailed information concerning pressure fluids note VDMA-document 24317 as well as DIN 51524 & 51502.

Special gaskets may be available depending on the utilized fluid.

In case of insecurity please consult Parker.

The pressure fluid must have an ignition temperature of at least 50 K above the maximum surface temperature of the valve (see EN 13463-5 and IEC 60079-4).

Operating Instructions

5. Operating instructions

Air bleeding of hydraulic system

During initial startup, after an oil change as well as after the opening of lines or valves the hydraulic system must be air bled.

Filter

The function and lifetime of the valve are strongly affected by the cleanliness of the fluid.

Purity level class of 18/16/13 acc. ISO4406 is required.

 Pay attention to maintenance details!

Flushing

It is recommended to flush the pipelines by short circuiting the pressure and return lines. This prevents the installation dirt from entering the valve.

6. Maintenance

 Maintenance procedures may only be carried out by specialist personnel. A detailed knowledge is required of how the machine is switched on and off and also of the necessary safety measures.

Regular maintenance is essential in prolonging the service life of the systems, and safeguards plant safety and operational availability. The following items must be checked at regular and short intervals:

- Oil level in tank
- Max. medium temperature
- Max. surface temperature
- Condition of the pressure fluid (sight check, colour and smell of hydraulic fluid)
- Operating pressures
- Preload pressure of pressure vessel (if present)
- No leaks at any system components
- Condition of the filter elements
- Condition of the hose lines
- Cleanliness of components

After a certain period of service, the hydraulic fluid must be replaced. The frequency of the change depends on the following circumstances:

- Type and grade of pressure fluid (ageing)
- Filtration
- Operating temperature and ambient conditions

Replacement of a coil

In case of a necessary replacement of a coil the disassembly and assembly instructions on drawing 35015707 (see next page) have to be observed. Before exchanging a coil the name plates of old and new coil have to be checked. It must be ensured that only coils with identical voltages are used.

Available coil kits are:

AK-D1VWCJEE93	24 V DC
AK-D1VWCPEE93	110 V / 50 Hz
AK-D1VWCNEE93	230 V / 50 Hz

The coils of series 93 are suitable for valves of series 91 as well as 92 and 93.

Demontage:

- Kabelverschraubung (6) lösen und abschrauben.
- Überwurfmutter (5) lösen und abschrauben, Distanzhülse (4) und Dichtung (3) abziehen.
- Spule (1) abziehen, O-Ring (2) entfernen.
- Prüfen, ob Fixierstift (7) noch OK ist. Wenn nein, aus Gehäuse ziehen und durch neuen Stift ersetzen, ansonsten im Gehäuse belassen.

Montage:

- O-Ring (2) aufschieben und am Gehäuse positionieren.
- Spule (1) in korrekter Ausrichtung aufschieben, anschließend Dichtung (3) aufschieben und nahe der Spule (1) positionieren, dann Distanzhülse (4) aufschieben und damit Dichtung (3) in die Spule (1) schieben.
- Überwurfmutter (5) aufschrauben und mit korrektem Drehmoment (siehe Zeichnung D14-2128D3.* für DC-Spulen bzw. K14-2074D3.* für AC-Spulen) anziehen.
- Anschließend Kabelverschraubung (6) nach Zeichnung 5005113 an Klemmkasten der Spule (1) montieren.

Disassembly:

- Declamp and unmount Cable gland (6).
- Declamp and unmount hex nut (5), spacer (4) and seal (3).
- Unmount coil (1) and remove O-ring (2).
- Check, if locating pin (7) is still OK. If not, pull out of body and replace by a new one, otherwise leave in body.

Assembly:

- Slide on O-ring (2) till it is close to the body.
- Slide on coil (1) in correct orientation, then slide on seal (3) till it is close to the coil (1), then slide on spacer (4) and then move together with seal (3) into coil (1).
- Screw hex nut (5) with correct torque (according to drawing D14-2128D3.* for DC-coils respectively K14-2074D3.* for AC-coils).
- Mount cable gland (6) to conduit box of coil (1) according to drawing 5005113.

Supersedes drawing	Material	Raw part	Change No.	15-JUL-2014, TT
ISOIR 128 A	Property of PARKER HANNIFIN To be returned with all copies upon completion of authorized use. Not for sale, purchase or copied without its written consent.			
Technical drawing	Technical drawing			
Geometrical tolerancing acc. to DIN ISO 1101	M. Approximation	10.05.2013		
Surface finish acc. to DIN ISO 1302	M. Scale	1:1		
General tolerance acc. to DIN ISO 2768-mK	Sheet	1/1		
Normal size	Size	35015707		
Part number	Parting number			
Tolerance				

Checked 2014

Prof. Stat. Pfr.-System Release
Dr. - Prototypen, No. 0010 Release

Parker Hannifin
Hydraulic Control Division
41504 Krahn (Germany)

Coil Exchange ATEX DCV
35015707
B PR

Operating Instructions

7. Troubleshooting

A systematic approach must always be used in the troubleshooting process. Begin by answering the following questions:

- Does anyone have practical experience of similar faults?
- Have any of the settings been changed in the system?

Now try to identify the fault using a prioritised list of the most likely causes.

- If you suspect that the valve is not moving freely, you should flush the valve with clean pressure fluid.

- A systematic approach should always be adopted when troubleshooting a hydraulic system.

The work must only be carried out by specialist personnel because detailed knowledge of the function and structure of the system is required. Always think carefully about changing settings or removing components. Before starting work, check that the system was working correctly before the fault occurred.

Following any repair, commissioning must be carried out as instructed.

malfunction at hydraulic load runtime								
								- not working in general
								- high frequency vibrations
								- low frequency vibrations
								- moves only in one direction
								- the speed fluctuates when the command value stays unchanged
								- the speed is different for each stroke direction
								- speed too low
								- drifts without command value signal
								Possible causes
								Remedy
X								Hydraulic pump/motor defective
								Replace hydraulic pump/motor
X		X	X	X	X	X		Drive overloaded
								Reduce pressure/speed, increase valve size
								Hydraulic fluid too viscous/cold
								Change fluid quality, bring system to operating temperature
X		X	X					Oil level in tank too low
								Top up pressure fluid
								Filter contaminated
								Clean/replace filter
X		X					X	Supply voltage too low
								Observe supply voltage range
	X							Supply voltage has too much ripple
								Reduce ripple
X			X				X	Command signal too low
								Increase command signal
	X							Command signal has too much ripple
								Reduce ripple
X								Electrical supply line broken
								Fix supply line
X	X	X	X	X		X	X	Connection sequence incorrect
								Correct connection sequence
X							X	Electrical supply line not shielding
								Change to shielded wiring

A1.

Standards, directives and provisions relating to the operation of systems in potentially explosive areas (extract)

1999/92/EC	Minimum requirements for improving the safety and health protection of workers potentially at risk from explosive atmospheres
2004/108/EC	Electromagnetic compatibility directive (EMC)
EN ISO 12100:2010	Safety of machinery – General principles for design risk assessment and risk reduction
EN 15198:2007	Methodology for risk assessment of non-electrical equipment and components for intended use in potentially explosive atmospheres
EN 60079-0:2009	Explosive atmospheres – Part 0: Equipment – General requirements
EN 60079-7:2007	Explosive atmospheres – Part 7: Equipment protection by increased safety “e”
EN 60079-14:2009	Explosive atmospheres – Part 14: Electrical installations design, selection and erection (IEC 60079-14:2013)
EN 60079-17:2014	Explosive atmospheres – Part 17: Electrical installations inspection and maintenance (IEC 60079-17:2013)
EN 60529:2014	Degrees of protection provided by enclosures (IP code) (IEC 60529:1989 + A1:1999 + A2:2013)
BetrSichV	Ordinance on industrial safety and health
TRBS 2153:2009	Technical rules for operating safety Avoiding ignition hazards as a result of electrostatic charges

Operating Instructions

Directional Control Valve Series D1VW Explosion Proof

A2. User guide – Solenoid

	REV. A SEE GENERAL INFORMATION B SEE GENERAL INFORMATION	DESCRIPTION COVER MOUNTED WITH M X Ø T-SCREWS TORQUE: 2.0-3.0Nm	REVOLUTIONS DATE APPROV. DRAWN BY CHECKED BY DATE																															
PART NUMBER: D14-212803-0																																		
TEMP. CLASS TEMP. RANGE FORCE (N) ± 0.05 FORCE (Lb) ± 0.01 (SEE NOTE #1) (SEE NOTE #1) (SEE NOTE #3) (SEE NOTE #3)																																		
<table border="1" style="width: 100%; border-collapse: collapse;"> <thead> <tr> <th>ITEM #</th> <th>ITEM</th> <th>PART NUMBER</th> <th>DESCRIPTION</th> <th>QTY.</th> </tr> </thead> <tbody> <tr> <td>1</td> <td>VALVE BODY</td> <td>H-1059</td> <td>VALVE</td> <td>1</td> </tr> <tr> <td>2</td> <td>SOLENOID ASSEMBLY</td> <td>H-1102</td> <td>SOLENOID</td> <td>1</td> </tr> <tr> <td>3</td> <td>VALVE BODY TO VALVE HOUSING</td> <td>W-2386-022</td> <td>VALVE HOUSING</td> <td>1</td> </tr> <tr> <td>4</td> <td>VALVE HOUSING</td> <td>H-2386-01</td> <td>VALVE HOUSING</td> <td>1</td> </tr> </tbody> </table>							ITEM #	ITEM	PART NUMBER	DESCRIPTION	QTY.	1	VALVE BODY	H-1059	VALVE	1	2	SOLENOID ASSEMBLY	H-1102	SOLENOID	1	3	VALVE BODY TO VALVE HOUSING	W-2386-022	VALVE HOUSING	1	4	VALVE HOUSING	H-2386-01	VALVE HOUSING	1			
ITEM #	ITEM	PART NUMBER	DESCRIPTION	QTY.																														
1	VALVE BODY	H-1059	VALVE	1																														
2	SOLENOID ASSEMBLY	H-1102	SOLENOID	1																														
3	VALVE BODY TO VALVE HOUSING	W-2386-022	VALVE HOUSING	1																														
4	VALVE HOUSING	H-2386-01	VALVE HOUSING	1																														
COIL SIZE CHART																																		
<table border="1" style="width: 100%; border-collapse: collapse;"> <thead> <tr> <th>COIL SIZE</th> <th>A</th> <th>B</th> <th>C</th> <th>D</th> <th>E</th> <th>F</th> </tr> </thead> <tbody> <tr> <td>2</td> <td>32.5 (1.28)</td> <td>19.0 (0.75)</td> <td>22.0 (0.87)</td> <td>15.0 (0.59)</td> <td>13.0 (0.51)</td> <td>18.0 (0.71)</td> </tr> <tr> <td>3</td> <td>42.5 (1.67)</td> <td>22.0 (0.87)</td> <td>28.0 (1.10)</td> <td>17.0 (0.67)</td> <td>15.0 (0.59)</td> <td>20.0 (0.79)</td> </tr> <tr> <td>4</td> <td>52.5 (2.07)</td> <td>25.0 (0.98)</td> <td>34.0 (1.34)</td> <td>19.0 (0.75)</td> <td>17.0 (0.67)</td> <td>23.0 (0.91)</td> </tr> </tbody> </table>							COIL SIZE	A	B	C	D	E	F	2	32.5 (1.28)	19.0 (0.75)	22.0 (0.87)	15.0 (0.59)	13.0 (0.51)	18.0 (0.71)	3	42.5 (1.67)	22.0 (0.87)	28.0 (1.10)	17.0 (0.67)	15.0 (0.59)	20.0 (0.79)	4	52.5 (2.07)	25.0 (0.98)	34.0 (1.34)	19.0 (0.75)	17.0 (0.67)	23.0 (0.91)
COIL SIZE	A	B	C	D	E	F																												
2	32.5 (1.28)	19.0 (0.75)	22.0 (0.87)	15.0 (0.59)	13.0 (0.51)	18.0 (0.71)																												
3	42.5 (1.67)	22.0 (0.87)	28.0 (1.10)	17.0 (0.67)	15.0 (0.59)	20.0 (0.79)																												
4	52.5 (2.07)	25.0 (0.98)	34.0 (1.34)	19.0 (0.75)	17.0 (0.67)	23.0 (0.91)																												
NOTES:																																		
1. DUTY - CONTINUOUS 2. MAX. STABILISED MATS RELATES TO STAB. USED. POWER CONSUMPTION AT THE COIL AND AMBIENT TEMPERATURE OF 20°C. 3. FORCE (PSI) @ 3.0mm (0.118") STROKE @ NOMINAL VOLTAGE @ 25°C (77°F). SEE CHART USING D14-2804 OR D14-2805 TUBE. 4. COIL OPER. TEMPERATURE MAY EXCEED 100°C. 5. USE IN CONJUNCTION WITH SUB CIRCUIT FUSE B888, IEC289, 6A MAX (DC). 6. DO NOT OPEN TERMINAL BOX WHILE ENERGISED. 7. SUBSTITUTION OF ANY COIL COMPONENTS (INCLUDING ALL FASTENERS) NOT SPECIFIED BY LISK MAY VOID CERTIFICATION. 8. THE SOLENOID MUST BE COMPLETELY ASSEMBLED WITH THE VALVE BEFORE THE SOLENOID COIL IS ENERGISED.																																		
WARNING: ELECTROSTATIC DISCHARGE (ESD) PROTECTIVE PRECAUTIONS MUST BE TAKEN THROUGHOUT THE ASSEMBLY AND TESTING PROCESS TO AVOID THE POSSIBILITY OF PRODUCT DAMAGE OR PERSONAL INJURY.																																		
WARNING: ELECTROSTATIC DISCHARGE (ESD) PROTECTIVE PRECAUTIONS MUST BE TAKEN THROUGHOUT THE ASSEMBLY AND TESTING PROCESS TO AVOID THE POSSIBILITY OF PRODUCT DAMAGE OR PERSONAL INJURY.																																		
WARNING: ELECTRICAL SAFETY: THIS VALVE IS NOT TO BE USED AS A SWITCH TO CONTROL A HIGH VOLTAGE LINE OR OTHER EQUIPMENT WITH THE POTENTIAL OF PERSONAL INJURY OR DEATH.																																		
WARNING: ELECTRICAL SAFETY: THIS VALVE IS NOT TO BE USED AS A SWITCH TO CONTROL A HIGH VOLTAGE LINE OR OTHER EQUIPMENT WITH THE POTENTIAL OF PERSONAL INJURY OR DEATH.																																		
CAUTION: ELECTRICAL SAFETY: THIS VALVE IS NOT TO BE USED AS A SWITCH TO CONTROL A HIGH VOLTAGE LINE OR OTHER EQUIPMENT WITH THE POTENTIAL OF PERSONAL INJURY OR DEATH.																																		
CAUTION: ELECTRICAL SAFETY: THIS VALVE IS NOT TO BE USED AS A SWITCH TO CONTROL A HIGH VOLTAGE LINE OR OTHER EQUIPMENT WITH THE POTENTIAL OF PERSONAL INJURY OR DEATH.																																		

REV.	DESCRIPTION	REVISIONS	DATE	APPR.
6				
5				
4				
3				
2				

PART NUMBER: K14-207403-*

INTERNAL WIRING DIAGRAM.

SECTION A-A
SCALE 0.600

COIL SIZE	A	B	C	D	E	F	REMARKS
2	2.8 (74)	2.8 (74)	1.4 (36)	1.4 (36)	1.4 (36)	1.4 (36)	4.9 (125)
3	3.8 (97)	3.8 (97)	1.4 (36)	1.4 (36)	1.4 (36)	1.4 (36)	5.9 (149)
4	4.8 (122)	4.8 (122)	1.4 (36)	1.4 (36)	1.4 (36)	1.4 (36)	7.0 (178)

COIL SIZE CHART

1. THIS SIZE ONLY BE USED WHEN THE VALVE IS MOUNTED TO A SURFACE OR IN A PANEL. THE COIL SIZE SHOULD BE GREATER THAN THE VALVE BODY WIDTH.

2. THE VALVE BODY IS DESIGNED TO ACCEPT COILS WITH A WIDTH OF 1.4 INCHES (36 MM).

3. THE VALVE BODY IS DESIGNED TO ACCEPT COILS WITH A HEIGHT OF 2.8 INCHES (71 MM).

4. THE VALVE BODY IS DESIGNED TO ACCEPT COILS WITH A DEPTH OF 1.4 INCHES (36 MM).

5. THE VALVE BODY IS DESIGNED TO ACCEPT COILS WITH A WEIGHT OF 1.4 LBS (0.63 KG).

6. THE VALVE BODY IS DESIGNED TO ACCEPT COILS WITH A LENGTH OF 1.4 INCHES (36 MM).

7. THE VALVE BODY IS DESIGNED TO ACCEPT COILS WITH A WIDTH OF 1.4 INCHES (36 MM).

8. THE VALVE BODY IS DESIGNED TO ACCEPT COILS WITH A HEIGHT OF 2.8 INCHES (71 MM).

9. THE VALVE BODY IS DESIGNED TO ACCEPT COILS WITH A DEPTH OF 1.4 INCHES (36 MM).

10. THE VALVE BODY IS DESIGNED TO ACCEPT COILS WITH A WEIGHT OF 1.4 LBS (0.63 KG).

11. THE VALVE BODY IS DESIGNED TO ACCEPT COILS WITH A LENGTH OF 1.4 INCHES (36 MM).

12. THE VALVE BODY IS DESIGNED TO ACCEPT COILS WITH A WIDTH OF 1.4 INCHES (36 MM).

13. THE VALVE BODY IS DESIGNED TO ACCEPT COILS WITH A HEIGHT OF 2.8 INCHES (71 MM).

14. THE VALVE BODY IS DESIGNED TO ACCEPT COILS WITH A DEPTH OF 1.4 INCHES (36 MM).

15. THE VALVE BODY IS DESIGNED TO ACCEPT COILS WITH A WEIGHT OF 1.4 LBS (0.63 KG).

16. THE VALVE BODY IS DESIGNED TO ACCEPT COILS WITH A LENGTH OF 1.4 INCHES (36 MM).

17. THE VALVE BODY IS DESIGNED TO ACCEPT COILS WITH A WIDTH OF 1.4 INCHES (36 MM).

18. THE VALVE BODY IS DESIGNED TO ACCEPT COILS WITH A HEIGHT OF 2.8 INCHES (71 MM).

19. THE VALVE BODY IS DESIGNED TO ACCEPT COILS WITH A DEPTH OF 1.4 INCHES (36 MM).

20. THE VALVE BODY IS DESIGNED TO ACCEPT COILS WITH A WEIGHT OF 1.4 LBS (0.63 KG).

COIL SIZE	A	B	C	D	E	F	REMARKS
2	2.8 (74)	2.8 (74)	1.4 (36)	1.4 (36)	1.4 (36)	1.4 (36)	4.9 (125)
3	3.8 (97)	3.8 (97)	1.4 (36)	1.4 (36)	1.4 (36)	1.4 (36)	5.9 (149)
4	4.8 (122)	4.8 (122)	1.4 (36)	1.4 (36)	1.4 (36)	1.4 (36)	7.0 (178)

COIL SIZE CHART

1. THIS SIZE ONLY BE USED WHEN THE VALVE IS MOUNTED TO A SURFACE OR IN A PANEL. THE COIL SIZE SHOULD BE GREATER THAN THE VALVE BODY WIDTH.

2. THE VALVE BODY IS DESIGNED TO ACCEPT COILS WITH A WIDTH OF 1.4 INCHES (36 MM).

3. THE VALVE BODY IS DESIGNED TO ACCEPT COILS WITH A HEIGHT OF 2.8 INCHES (71 MM).

4. THE VALVE BODY IS DESIGNED TO ACCEPT COILS WITH A DEPTH OF 1.4 INCHES (36 MM).

5. THE VALVE BODY IS DESIGNED TO ACCEPT COILS WITH A WEIGHT OF 1.4 LBS (0.63 KG).

6. THE VALVE BODY IS DESIGNED TO ACCEPT COILS WITH A LENGTH OF 1.4 INCHES (36 MM).

7. THE VALVE BODY IS DESIGNED TO ACCEPT COILS WITH A WIDTH OF 1.4 INCHES (36 MM).

8. THE VALVE BODY IS DESIGNED TO ACCEPT COILS WITH A HEIGHT OF 2.8 INCHES (71 MM).

9. THE VALVE BODY IS DESIGNED TO ACCEPT COILS WITH A DEPTH OF 1.4 INCHES (36 MM).

10. THE VALVE BODY IS DESIGNED TO ACCEPT COILS WITH A WEIGHT OF 1.4 LBS (0.63 KG).

11. THE VALVE BODY IS DESIGNED TO ACCEPT COILS WITH A LENGTH OF 1.4 INCHES (36 MM).

12. THE VALVE BODY IS DESIGNED TO ACCEPT COILS WITH A WIDTH OF 1.4 INCHES (36 MM).

13. THE VALVE BODY IS DESIGNED TO ACCEPT COILS WITH A HEIGHT OF 2.8 INCHES (71 MM).

14. THE VALVE BODY IS DESIGNED TO ACCEPT COILS WITH A DEPTH OF 1.4 INCHES (36 MM).

15. THE VALVE BODY IS DESIGNED TO ACCEPT COILS WITH A WEIGHT OF 1.4 LBS (0.63 KG).

16. THE VALVE BODY IS DESIGNED TO ACCEPT COILS WITH A LENGTH OF 1.4 INCHES (36 MM).

17. THE VALVE BODY IS DESIGNED TO ACCEPT COILS WITH A WIDTH OF 1.4 INCHES (36 MM).

18. THE VALVE BODY IS DESIGNED TO ACCEPT COILS WITH A HEIGHT OF 2.8 INCHES (71 MM).

19. THE VALVE BODY IS DESIGNED TO ACCEPT COILS WITH A DEPTH OF 1.4 INCHES (36 MM).

20. THE VALVE BODY IS DESIGNED TO ACCEPT COILS WITH A WEIGHT OF 1.4 LBS (0.63 KG).

NOTES

1. DUTY - CONTINUOUS
2. Mkt. STABILIZED WTS. AMPS RELATES TO STABILIZED POWER CONSUMPTION AT THE COIL INPUT. THE VALVE IS DESIGNED TO ACCEPT COILS WITH A WEIGHT OF 1.4 LBS (0.63 KG).
3. FORCE (PUSH) 0.5mm (0.118in) STROKE @ NOMINAL VOLTAGE @ 50°C (175°F) I
4. COIL ENTRY USING D142-084 OR D142-085 HOSES.
5. COIL ENTRY TEMPERATURE MAY EXCEED 50°C.
6. USE IN CONNECTION WITH SUB CIRCUIT FUSE BRK. (IC699-26 MAX INCH).
7. DO NOT REMOVE TERMINAL BOX WHILE ENERGIZED COILS.
8. THE VALVE BODY IS DESIGNED TO ACCEPT COILS WITH A WEIGHT OF 1.4 LBS (0.63 KG).
9. THE VALVE BODY IS DESIGNED TO ACCEPT COILS WITH A LENGTH OF 1.4 INCHES (36 MM).
10. THE VALVE BODY IS DESIGNED TO ACCEPT COILS WITH A WIDTH OF 1.4 INCHES (36 MM).
11. THE VALVE BODY IS DESIGNED TO ACCEPT COILS WITH A HEIGHT OF 2.8 INCHES (71 MM).
12. THE VALVE BODY IS DESIGNED TO ACCEPT COILS WITH A DEPTH OF 1.4 INCHES (36 MM).
13. THE VALVE BODY IS DESIGNED TO ACCEPT COILS WITH A WEIGHT OF 1.4 LBS (0.63 KG).
14. THE VALVE BODY IS DESIGNED TO ACCEPT COILS WITH A LENGTH OF 1.4 INCHES (36 MM).
15. THE VALVE BODY IS DESIGNED TO ACCEPT COILS WITH A WIDTH OF 1.4 INCHES (36 MM).
16. THE VALVE BODY IS DESIGNED TO ACCEPT COILS WITH A HEIGHT OF 2.8 INCHES (71 MM).
17. THE VALVE BODY IS DESIGNED TO ACCEPT COILS WITH A DEPTH OF 1.4 INCHES (36 MM).
18. THE VALVE BODY IS DESIGNED TO ACCEPT COILS WITH A WEIGHT OF 1.4 LBS (0.63 KG).
19. THE VALVE BODY IS DESIGNED TO ACCEPT COILS WITH A LENGTH OF 1.4 INCHES (36 MM).
20. THE VALVE BODY IS DESIGNED TO ACCEPT COILS WITH A WIDTH OF 1.4 INCHES (36 MM).

ITEM	PART NUMBER	DESCRIPTION	QTY.
1	H-23880-1	VALVE BODY	1
2	H-23880-2	O-RING	1
3	H-23880-3	COIL ASSEMBLY	1
4	H-23880-4	COIL ASSEMBLY	1
5	H-23880-5	VALVE BODY	1
6	H-23880-6	VALVE BODY	1

REV.	DESCRIPTION	DATE	APPR.
6			
5			
4			
3			
2			

COIL

PART No. K14-207403-*

SIZE SCALE: 1:1000 SHEET NO. 1 of 1

REVISIONS			
REV	DESCRIPTION	DATE	APPROVED
A	SEE EOND14-208REV1A	07-APR-08	R.D.
B	SEE EOND14-208REV2B	28-AUG-08	R.D.
C	SEE EOND14-208REV3C	02-JUL-14	R.D.

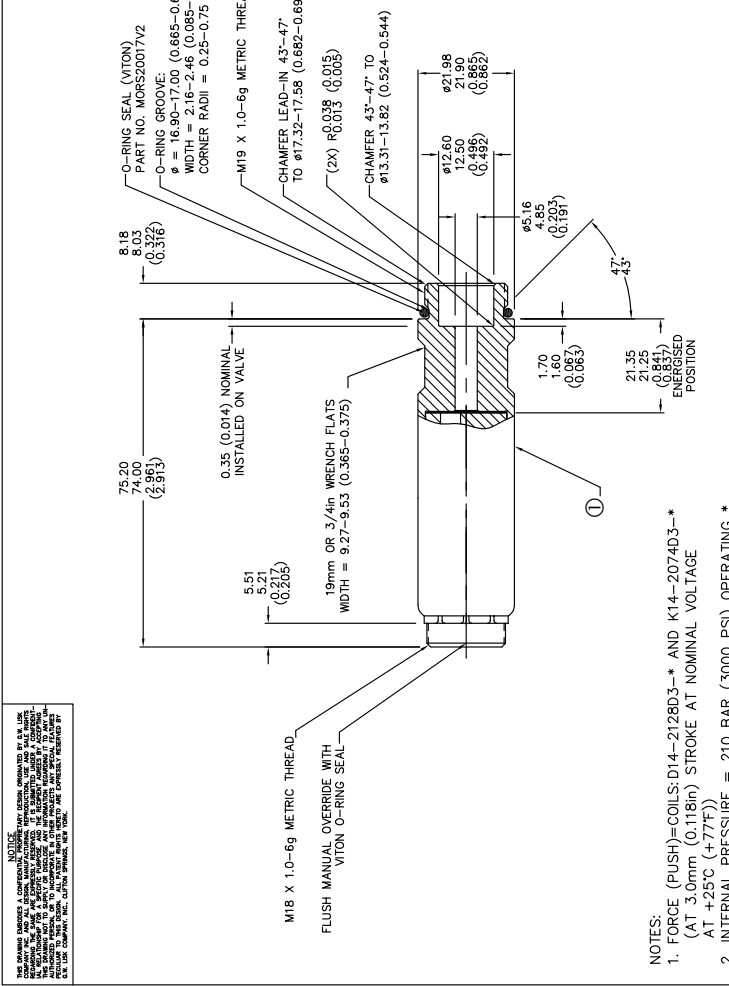

NOTICE:
PARKER HANNIFIN CORPORATION, VALVE DIVISION, 1000 W. 14TH STREET, MUSKOGEE, OKLAHOMA 74403, U.S.A.
THIS DRAWING IS THE PROPERTY OF PARKER HANNIFIN CORPORATION. IT IS TO BE USED FOR THE MANUFACTURE OF THE VALVE DESCRIBED HEREON. IT IS NOT TO BE REPRODUCED, COPIED, OR TRANSMITTED IN ANY FORM OR BY ANY MEANS, ELECTRONIC OR MECHANICAL, INCLUDING PHOTOCOPYING, RECORDING, OR BY ANY INFORMATION STORAGE AND RETRIEVAL SYSTEM, WITHOUT THE WRITTEN PERMISSION OF PARKER HANNIFIN CORPORATION. ALL DIMENSIONS ARE IN MILLIMETERS UNLESS OTHERWISE SPECIFIED.
PARKER HANNIFIN CORPORATION, VALVE DIVISION, 1000 W. 14TH STREET, MUSKOGEE, OKLAHOMA 74403, U.S.A.

- NOTES:
- FORCE (PUSH)=COILS:D14-2128D3-* AND K14-2074D3-* (AT 3.0mm (0.118in) STROKE AT NOMINAL VOLTAGE AT +25°C (+77°F))
 - INTERNAL PRESSURE = 210 BAR (3000 PSI) OPERATING * = 210 BAR (3000 PSI) STATIC * SPIKES AND/OR SURGES.
 - OPERATING PRESSURE IS PULSING PRESSURE INCLUDING PLUNGER TRAVEL 6.1mm (0.240in) MIN.
 - PROTECTIVE CAPS FOR INTERFACE THREAD SUPPLIED BY LISK IRELAND.

UNLESS OTHERWISE SPECIFIED	INCH	3/4 ANGLE PROX.	DRAWN	TUBE ASSEMBLY
TO FINISH ALL OVER	[mm]		I. T. 12-APR-07	1
F- APPEARANCE ONLY			CHECK K. L. 20-APR-07	QTY
ALL DIMETERS CONCENTRIC			ENGINEER	DESCRIPTION
BREAK ALL SHARP EDGES				LISK IRELAND LTD.
FINISH				ENNIS ROAD CORT CO GALWAY IRELAND
±-RADIUS OR CHAMFER ACCEPTABLE				T U B E
				SEE DWG NO D14-2084
				REV
				WEIGHT
				SHEET 1 OF 1

Operating Instructions

Directional Control Valve Series D1VW Explosion Proof

REVISIONS			
REV	DESCRIPTION	DATE	APPROVED
A	SEE EOND14-208REV1A	07-APR-08	R.D.
B	SEE EOND14-208REV1B	26-AUG-08	R.D.
C	SEE EOND14-208REV1C	02-JUL-14	R.D.

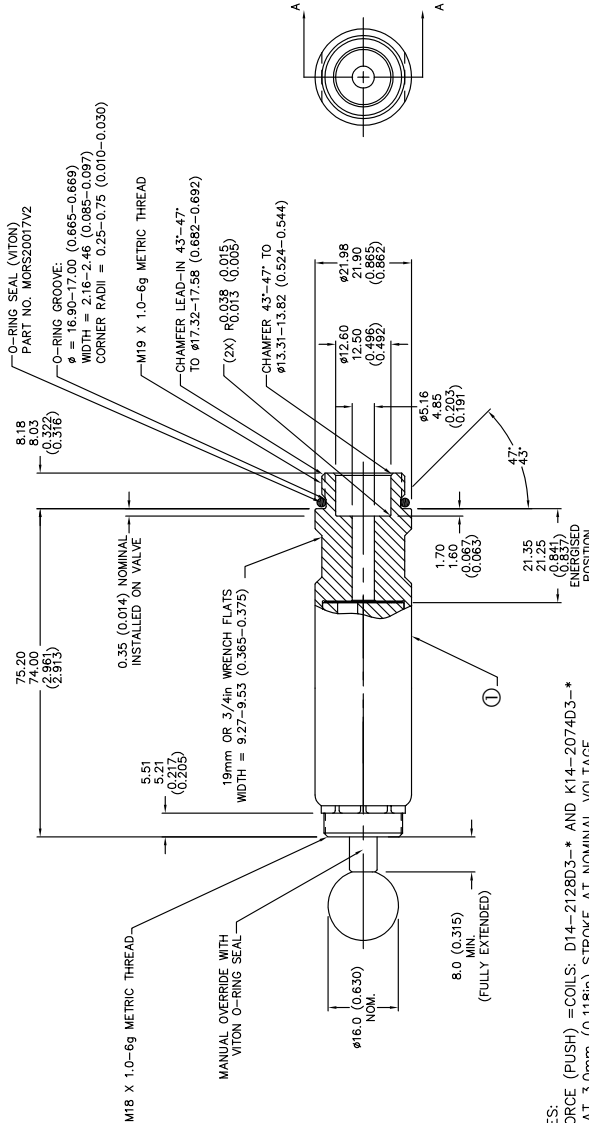

NOTICE
THIS DRAWING IS A CONFIDENTIAL PROPERTY OF PARKER HANNIFIN COMPANY. IT IS THE PROPERTY OF PARKER HANNIFIN COMPANY AND IS LOANED TO YOU BY PARKER HANNIFIN COMPANY. IT IS NOT TO BE REPRODUCED, COPIED, OR TRANSMITTED IN ANY FORM OR BY ANY MEANS, ELECTRONIC OR MECHANICAL, INCLUDING PHOTOCOPYING, RECORDING, OR BY ANY INFORMATION STORAGE AND RETRIEVAL SYSTEM, WITHOUT THE WRITTEN PERMISSION OF PARKER HANNIFIN COMPANY. IN THE EVENT OF A DISCREPANCY BETWEEN THIS DRAWING AND ANY OTHER DRAWING OR DOCUMENT, THIS DRAWING SHALL PREVAIL. PARKER HANNIFIN COMPANY, 100 PARKER DRIVE, COLUMBIANA, OHIO 43086, U.S.A. © 2014 PARKER HANNIFIN COMPANY. ALL RIGHTS RESERVED.

- NOTES:
- FORCE (PUSH) = COILS: D14-2128D3-* AND K14-2074D3-* (AT 3.0mm (0.118in) STROKE AT NOMINAL VOLTAGE AT +25°C (+77°F))
 - INTERNAL PRESSURE = 210 BAR (3000 PSI) OPERATING *
*OPERATING PRESSURE IS PULSING PRESSURE INCLUDING SPIKES AND/OR SURGES.
 - PLUNGER TRAVEL 6.1mm (0.240in) MIN.
 - PROTECTIVE CAPS FOR INTERFACE THREAD SUPPLIED BY LISK IRELAND.

ITEM	PART NUMBER	TUBE ASSEMBLY	QTY
1	H-22848		1

LISK IRELAND LTD		ENNIS ROAD, COBT. CO. GALWAY, IRELAND	
INCH	3/4 ANGLE PROX.	BRAIN.	R.D. 30MAV07
[mm]		CHECK	R.D. 31MAY07
MATERIAL		ENGINEER	
FINISH		PARKER T1-DVPE00	
DO NOT SCALE		WEIGHT	
SIZE A3		DWG NO D14-2085	
REV C		SHEET 1 OF 1	



A3. Type-examination certificate – Solenoid

Certificate Number
Baseefa02ATEX0199X



Issued 6 February 2003
Page 1 of 3

1 EC - TYPE EXAMINATION CERTIFICATE

**2 Equipment or Protective System Intended for use in Potentially Explosive Atmospheres
Directive 94/9/EC**

3 EC – Type Examination Certificate Baseefa02ATEX0199X
Number :

4 Equipment or protective system: The Type D/K XX-XD-XD Solenoids

5 Manufacturer : G.W. Lisk Company Incorporated

6 Address : 2 South Street, Clifton Springs, New York, 14432, USA

7 This equipment and any acceptable variation thereto is specified in the schedule to this certificate and the documents therein referred to.

8 Baseefa (2001) Ltd. Notified body number 1180 in accordance with Article 9 of the Council Directive 94/9/EC of 23 March 1994, certifies that this equipment or protective system has been found to comply with the Essential Health and Safety Requirements relating to the design and construction of equipment and protective systems intended for use in potentially explosive atmospheres given in Annex II to the Directive.

The examination and test results are recorded in confidential Report No. 02(C)0465

9 Compliance with the Essential Health and Safety Requirements has been assured by compliance with:

EN 50014 (1997) + Amendments 1 & 2; EN 50019 (2000); EN 50028 (1987)

except in respect of those requirements listed at item 18 of the Schedule.

10 If the sign "X" is placed after the certificate number, it indicates that the equipment or protective system is subject to special conditions of safe use specified in the schedule to this certificate.

11 This EC - TYPE EXAMINATION CERTIFICATE relates only to the design and construction of the specified equipment or protective system. If applicable, further requirements of this Directive apply to the manufacture and supply of this equipment or protective system.

12 The marking of the equipment or protective system shall include the following :

⊕ II 2G EEx me II T(See Schedule) -54°C ≤ T_{amb} ≤ +40°C or -54°C ≤ T_{amb} ≤ +60°C

This certificate may only be reproduced in its entirety, without any change, schedule included.

Baseefa (2001) Ltd. Customer Reference No. 0435

Project File No.02/0465

This certificate is granted subject to the general terms and conditions of Baseefa (2001) Ltd. It does not necessarily indicate that the equipment may be used in particular industries or circumstances.

R S SINCLAIR

DIRECTOR

**On behalf of
Baseefa (2001) Ltd.**

Baseefa (2001) Ltd.

Health and Safety Laboratory Site, Harpur Hill,
Buxton, Derbyshire SK17 9JN

Telephone +44 (0) 1298 28255 Fax +44 (0) 1298 28216

e-mail info@baseefa2001.biz web site www.baseefa2001.biz

Registered in England No. 4305578 at 13 Dovedale Crescent, Buxton,
Derbyshire, SK17 9BJ

Certificate Number
Baseefa02ATEX0199X



Issued 6 February 2003
Page 2 of 3

Schedule

15 Description of Equipment or Protective System

The Type D/K XX-XD-XD Solenoids comprise an encapsulated coil solenoid fitted with an increased safety terminal enclosure. Additionally the Type K solenoids are fitted with a bridge rectifier and a shunt varistor. The coil and components are encapsulated in a glass fibre filled polyester resin.

The solenoid is fitted to a core tube, which contains the solenoid armature. The core tube is provided with a mounting thread to customer specification. The solenoid is retained on the core tube by a spacer and nut.

Internal and external earth facilities are provided.

An M20 cable entry is provided for connection of the users cabling.

The solenoid is designed and rated for mounting on a specified valve body (see sheet 8 of drawing number H17423).

The Type designation represents the following information;

- i) The first character is either D for d.c. input or K for a.c. input.
- ii) The first two digits (10, 12, 13, 14, 15, 16, 17, 18 or 19) identify the diameter of the core tube in 1/16 inches.
- iii) The subsequent 1, 2, 3, or 4 digits identify information specific to the customer. Associated with these digits is the character D which indicates that the coil is an explosion protection design (EEx me).
- iv) The final group of 3 numbers signify the voltage and wattage ratings.

Both d.c. and a.c. versions are fitted with a thermal fuse rated with an operating temperature according to the applicable temperature classification as follows;

- For T6 versions a 75°C rated thermal fuse is fitted.
- For T5 versions a 90°C rated thermal fuse is fitted.
- For T4 versions a 125°C rated thermal fuse is fitted.

The solenoid coil may be wound for use with supplies of up to 250V d.c. (Type D) or 250V a.c. 50Hz or 60Hz (Type K). The maximum stabilized power dissipation for a given maximum ambient temperature and temperature classification for the solenoid mounted on a specified valve body are given in the table below.

MAXIMUM PERMITTED STABILIZED POWER (Watts)

Solenoid Type	Ambient Temperature (°C)	Power (Watts)		
		T6	T5	T4
D10, K10	40	12	18	30
	60	6	11	25
D12, K12, D13, K13, D14, K14, D15, K15	40	13	22	36
	60	4	11	30
D14, K14, D15, K15	40	16	23	39
	60	7	13	30
D16, K16, D17, K17, D18, K18, D19, K19	40	25	37	50
	60	10	22	42

Certificate Number
Baseefa02ATEX0199X



Issued 6 February 2003
Page 3 of 3

16 Report No. 02(C)0465

17 **Special Conditions for Safe Use**

1. The solenoid must only be mounted on a valve body which has a heat dissipation equal to or greater than the valve body shown on sheet 8 of drawing number H17423. The solenoid valve must be complete before the coil is energised.
2. The solenoid and the valve body on which it is mounted must not be thermally lagged.
3. The fluid flowing through the valve must not exceed the specified ambient temperature of 40°C or 60°C.
4. The solenoid shall be protected by fuses rated for a prospective short circuit current of at least 4000A.

18 **Essential Health and Safety Requirements**

None additional to those covered by the standards listed at item 9

19 **Drawings and Documents**

<u>Number</u>	<u>Issue</u>	<u>Date</u>	<u>Description</u>
H17423 sheet 1	A	05 Jun 01	General Arrangement
H17423 sheet 2	A	05 Jun 01	Dimensional Details
H17423 sheet 3	A	05 Jun 01	Terminal Box
H17423 sheet 4	A	05 Jun 01	Circuit Details
H17423 sheet 5	A	05 Jun 01	Coil Details
H17423 sheet 6	A	05 Jun 01	Certification Label
H17423 sheet 7	A	05 Jun 01	Voltage & Power Ratings
H17423 sheet 8	A	05 Jun 01	Heat Sink (Valve Body) Details
H17423 sheet 9	A	05 Jun 01	Encapsulant Details

Certificate Number
Baseefa02ATEX0199X/1



Issued 8th April 2009
Page 1 of 2

1 **SUPPLEMENTARY EC - TYPE EXAMINATION CERTIFICATE**

2 **Equipment or Protective System Intended for use in Potentially Explosive Atmospheres
Directive 94/9/EC**

3 Supplementary EC - Type Examination Certificate Number: **Baseefa02ATEX0199X/1**

4 Equipment or Protective System: **The Type D/K XX-XD-XD Solenoids**

5 Manufacturer: **G.W. Lisk Company Incorporated**

6 Address: **2 South Street, Clifton Springs, New York 14432, USA**

7 This supplementary certificate extends EC – Type Examination Certificate No. Baseefa02ATEX0199X to apply to equipment or protective systems designed and constructed in accordance with the specification set out in the Schedule of the said certificate but having any variations specified in the Schedule attached to this certificate and the documents therein referred to.

This supplementary certificate shall be held with the original certificate.

This certificate may only be reproduced in its entirety, without any change, schedule included.

Baseefa Customer Reference No. 0435

Project File No. 09/0188

This certificate is granted subject to the general terms and conditions of Baseefa. It does not necessarily indicate that the equipment may be used in particular industries or circumstances.

Baseefa

Rockhead Business Park, Staden Lane,
Buxton, Derbyshire SK17 9RZ
Telephone +44 (0) 1298 766600 Fax +44 (0) 1298 766601
e-mail info@baseefa.com web site www.baseefa.com
Baseefa is a trading name of Baseefa Ltd
Registered in England No. 4305578. Registered address as above.

R S SINCLAIR
DIRECTOR
On behalf of
Baseefa

Certificate Number
Baseefa02ATEX0199X/1



Issued 8th April 2009
Page 2 of 2

13

Schedule

14

Certificate Number Baseefa02ATEX0199X/1

15 Description of the variation to the Equipment or Protective System

Variation 1.1

To confirm that the equipment covered by this certificate has been reviewed against the requirements of EN 60079-0: 2006, EN 60079-7: 2007 and EN 60079-18: 2004 in respect of the differences from EN 50014: 1997 + amd. 1 & 2, EN 50019: 2000 and EN 50028: 1987 and that none of these differences in the Standard affects this equipment.

Variation 1.2

To permit minor design and drawing changes.

16 Report Number

None

17 Special Conditions for Safe Use

None additional to those listed previously

18 Essential Health and Safety Requirements

Compliance with the Essential Health and Safety Requirements is not affected by this variation.

19 Drawings and Documents

Number	Sheet	Issue	Date	Description
H17423	1	B	20 Feb 09	General arrangement
H17423	2	B	20 Feb 09	Dimensional detail
H17423	3	B	20 Feb 09	Terminal box
H17423	4	B	20 Feb 09	Circuit details
H17423	5	B	20 Feb 09	Coil details
H17423	6	B	20 Feb 09	Certification label
H17423	7	B	20 Feb 09	Voltage and power ratings
H17423	8	B	20 Feb 09	Heat sink (valve body) details
H17423	9	B	20 Feb 09	Encapsulant details

Certificate Number
Baseefa02ATEX0199X/2



Issued 26 October 2012
Page 1 of 3

1 SUPPLEMENTARY EC - TYPE EXAMINATION CERTIFICATE

**2 Equipment or Protective System Intended for use in Potentially Explosive Atmospheres
Directive 94/9/EC**

3 Supplementary EC - Type Examination Certificate Number: Baseefa02ATEX0199X/2

4 Equipment or Protective System: The Type D/K XX-XD-XD Solenoids

5 Manufacturer: G.W. Lisk Company Incorporated

6 Address: 2 South Street, Clifton Springs, New York 14432, USA

7 This supplementary certificate extends EC - Type Examination Certificate No. Baseefa02ATEX0199X to apply to equipment or protective systems designed and constructed in accordance with the specification set out in the Schedule of the said certificate but having any variations specified in the Schedule attached to this certificate and the documents therein referred to.

8 Item 9 of the original Certificate is replaced by "Compliance with the Essential Health and Safety Requirements has been assured by compliance with:

EN60079-0: 2012 EN60079-7: 2007 EN60079-18: 2009

except in respect of those requirements listed at item 18 of the Schedule."

9 The marking of the equipment has changed from the original Certificate and shall include the following:

Ⓢ II 2 G Ex e mb T* Gb Ta -40°C to +°C * See schedule**

This certificate shall be held with the original certificate and may only be reproduced in its entirety, without any change, schedule included.

Baseefa Customer Reference No. 0435

Project File No. 10/0568

This certificate is granted subject to the general terms and conditions of Baseefa. It does not necessarily indicate that the equipment may be used in particular industries or circumstances.

Baseefa
Rockhead Business Park, Staden Lane,
Buxton, Derbyshire SK17 9RZ
Telephone +44 (0) 1298 766600 Fax +44 (0) 1298 766601
e-mail info@baseefa.com web site www.baseefa.com
Baseefa is a trading name of Baseefa Ltd
Registered in England No. 4305578. Registered address as above.

R S SINCLAIR
DIRECTOR
On behalf of
Baseefa

Certificate Number
Baseefa02ATEX0199X/2



Issued 26 October 2012
Page 2 of 3

13

Schedule

14

Certificate Number Baseefa02ATEX0199X/2

15 Description of the variation to the Equipment or Protective System

Variation 2.1

To confirm that the equipment covered by this certificate has been reviewed against the requirements of EN 60079-0: 2012, and EN 60079-18: 2009.

Variation 2.2

To permit alternative ratings at 50°C ambient temperature. The maximum stabilised power for the temperature classification and ambient temperature range for each size of solenoid is indicated below.

Coil size	Ambient temperature (°C)	Maximum Stabilised Power (W)		
		T4	T5	T6
1	-40°C to +40°C	18	14	9
	-40°C to +60°C	14	8	3
2	-40°C to +40°C	21.5	15.4	10.8
	-40°C to +50°C	18.9	12.3	7.9
	-40°C to +60°C	16.4	9.3	5.1
3	-40°C to +40°C	22.2	16.4	11.4
	-40°C to +50°C	19.5	13.0	8.4
	-40°C to +60°C	16.8	9.9	5.5
4	-40°C to +40°C	34.1	21.3	15.1
	-40°C to +50°C	29.8	17.1	11.1
	-40°C to +60°C	25.6	13.1	7.3

The table above supersedes the previously permitted wattages.

Variation 2.3

Deletion of the use of a varistor.

Variation 2.4

The use of thermal fuses to be optional.

16 Report Number

Baseefa certification report 10(C)0568.

17 Specific Conditions of Use

The solenoids shall be protected by fuses rated for a prospective short circuit current of at least 1500A.

18 Essential Health and Safety Requirements

Compliance with the Essential Health and Safety Requirements is not affected by this variation.

Certificate Number
Baseefa02ATEX0199X/2



Issued 26 October 2012
Page 3 of 3

19 Drawings and Documents

Number	Sheet	Issue	Date	Description
H17423	1	C	14 Sept 2012	General Assembly
H17423	2	C	14 Sept 2012	General Assembly and sizes
H17423	3	C	14 Sept 2012	Terminal Box Details
H17423	4	C	14 Sept 2012	Internal Components and Wiring Details
H17423	5	C	14 Sept 2012	Winding Details
H17423	6	C	14 Sept 2012	Marking Details
H17423	7	C	14 Sept 2012	Power Details
H17423	8	C	14 Sept 2012	Valve and Subplate details
H17423	9	C	14 Sept 2012	Compound Details

Certificate Number
Baseefa02ATEX0199X/3



Issued 16 May 2014
Page 1 of 2

1 SUPPLEMENTARY EC - TYPE EXAMINATION CERTIFICATE

**2 Equipment or Protective System Intended for use in Potentially Explosive Atmospheres
Directive 94/9/EC**

3 Supplementary EC - Type Examination Certificate Number: Baseefa02ATEX0199X/3

4 Equipment or Protective System: Type D/KXX-XXXX-XX Solenoids

5 Manufacturer: G.W. Lisk Company Incorporated

6 Address: 2 South Street, Clifton Springs, New York 14432, USA

7 This supplementary certificate extends EC – Type Examination Certificate No. Baseefa02ATEX0199X to apply to equipment or protective systems designed and constructed in accordance with the specification set out in the Schedule of the said certificate but having any variations specified in the Schedule attached to this certificate and the documents therein referred to.

This supplementary certificate shall be held with the original certificate.

Baseefa Customer Reference No. 0435

Project File No. 13/0686

This document is issued by the Company subject to its General Conditions for Certification Services accessible at <http://www.sgs.com/en/Terms-and-Conditions.aspx> and the Supplementary Terms and Conditions accessible at <http://www.baseefa.com/terms-and-conditions.asp>. Attention is drawn to the limitation of liability, indemnification and jurisdiction issues defined therein. Any holder of this document is advised that information contained herein reflects the Company's findings at the time of its intervention only and within the limits of Client's instructions, if any. It does not necessarily indicate that the equipment may be used in particular industries or circumstances. The Company's sole responsibility is to its Client and this document does not exonerate parties to a transaction from exercising all their rights and obligations under the transaction documents. This document cannot be reproduced except in full, schedule included, without prior written approval of the Company. Any unauthorized alteration, forgery or falsification of the content or appearance of this document is unlawful and offenders may be prosecuted to the fullest extent of the law.

SGS Baseefa Limited

Rockhead Business Park, Staden Lane,
Buxton, Derbyshire SK17 9RZ

Telephone +44 (0) 1298 766600 Fax +44 (0) 1298 766601
e-mail info@baseefa.com web site www.baseefa.com

Registered in England No. 4305578.

Registered address: Rossmore Business Park, Ellesmere Port, Cheshire, CH65 3EN

R S SINCLAIR
GENERAL MANAGER
On behalf of SGS Baseefa Limited

Certificate Number
Baseefa02ATEX0199X/3



Issued 16 May 2014
Page 2 of 2

13

Schedule

14

Certificate Number Baseefa02ATEX0199X/3

15 **Description of the variation to the Equipment or Protective System**

Variation 3.1

To permit the option of an alternative terminal enclosure with two cable entries.

Variation 3.2

To note minor modifications and rewording of the Specific Conditions of Use.

16 **Report Number**

GB/BAS/ExTR13.0206/00.

17 **Specific Conditions of Use**

- 1 The solenoid must only be used on valve sizes with heat dissipation specified by the manufacturer of the solenoid in the instructions. The solenoid must be completely assembled with the valve before the solenoid is energised.
- 2 The solenoid and the valve on which it is mounted must not be thermally lagged.
- 3 The fluid flowing through the valve must not exceed the specified ambient temperature.
- 4 The solenoid shall be protected by a fuse rated for a prospective short circuit current of at least 1500A.

18 **Essential Health and Safety Requirements**

Compliance with the Essential Health and Safety Requirements is not affected by this variation.

19 **Drawings and Documents**

Number	Sheet	Issue	Date	Description
H17423	1	D	23.Apr.14	General Assembly
H17423	2	D	23.Apr.14	General Assembly and Sizes
H17423	3	D	23.Apr.14	Terminal Box Details
H17423	4	D	23.Apr.14	Internal Components and Wiring Details
H17423	5	D	23.Apr.14	Winding Details
H17423	6	D	23.Apr.14	Marking Details
H17423	7	D	23.Apr.14	Power Details
H17423	8	D	23.Apr.14	Valve and Subplate Details
H17423	9	D	23.Apr.14	Compound Details
H17423	10	D	23.Apr.14	Alternative Terminal Enclosure



IECEx Certificate of Conformity

INTERNATIONAL ELECTROTECHNICAL COMMISSION
IEC Certification Scheme for Explosive Atmospheres

for rules and details of the IECEx Scheme visit www.iecex.com

Certificate No.:	IECEx BAS 13.0093X	Issue No: 0	Certificate history: Issue No. 0 (2014-05-16)
Status:	Current	Page 1 of 3	
Date of Issue:	2014-05-16		
Applicant:	G.W. Lisk Company Incorporated 2 South Street Clifton Springs New York 14432 United States of America		
Electrical Apparatus:	Type D/XXX-XXXX-XX solenoids		
Optional accessory:			
Type of Protection:	Increased safety and Encapsulation		
Marking:	Ex e mb IIC T ⁺ Gb Ta -40°C to + ***C		

Approved for issue on behalf of the IECEx
Certification Body:

R S Sinclair

Position:

General Manager

Signature:
(for printed version)

Date:

1. This certificate and schedule may only be reproduced in full.
2. This certificate is not transferable and remains the property of the issuing body.
3. The Status and authenticity of this certificate may be verified by visiting the Official IECEx Website.

Certificate issued by:

SGS Baseefa Limited
Rockhead Business Park
Staden Lane
Buxton
Derbyshire
SK17 9RZ
United Kingdom





IECEX Certificate of Conformity

Certificate No:	IECEX BAS 13.0093X	Issue No: 0
Date of Issue:	2014-05-16	Page 2 of 3
Manufacturer:	G.W. Lisk Company Incorporated 2 South Street Clifton Springs New York 14432 United States of America	

Additional Manufacturing location(s):
Lisk Ireland Manufacturing Limited
 Ennis Road
 Gort
 County Galway
 Ireland

This certificate is issued as verification that a sample(s), representative of production, was assessed and tested and found to comply with the IEC Standard list below and that the manufacturer's quality system, relating to the Ex products covered by this certificate, was assessed and found to comply with the IECEx Quality system requirements. This certificate is granted subject to the conditions as set out in IECEx Scheme Rules, IECEx 02 and Operational Documents as amended.

STANDARDS:

The electrical apparatus and any acceptable variations to it specified in the schedule of this certificate and the identified documents, was found to comply with the following standards:

- | | |
|------------------------------------|--|
| IEC 60079-0 : 2011
Edition:6.0 | Explosive atmospheres - Part 0: General requirements |
| IEC 60079-18 : 2009
Edition:3 | Explosive atmospheres Part 18: Equipment protection by encapsulation "m" |
| IEC 60079-7 : 2006-07
Edition:4 | Explosive atmospheres - Part 7: Equipment protection by increased safety "e" |

This Certificate does not indicate compliance with electrical safety and performance requirements other than those expressly included in the Standards listed above.

TEST & ASSESSMENT REPORTS:

A sample(s) of the equipment listed has successfully met the examination and test requirements as recorded in

Test Report:

GB/BAS/ExTR13.0206/00

Quality Assessment Report:

GB/BAS/QAR11.0009/02 GB/BAS/QAR14.0006/00



IECEx Certificate of Conformity

Certificate No: IECEx BAS 13.0093X

Issue No: 0

Date of Issue: 2014-05-16

Page 3 of 3

Schedule

EQUIPMENT:

Equipment and systems covered by this certificate are as follows:

The Type D/KXX-XXXX-XX solenoids comprise an encapsulated solenoid coil and an increased safety terminal enclosure. The solenoid is fitted to a core tube which contains the solenoid armature. The core tube is provided with a mounting thread to customer specification. The solenoid is retained on the core tube by a spacer and nut. A bridge rectifier or four diodes and a thermal cut-out may optionally be provided within the encapsulation.

The stainless steel terminal enclosure contains a type MK 6/2 2 way terminal block to IEC05.0037U, and an internal earth facility. The enclosure has a cover with a gasket and up to two M20 cable entries.

The solenoids are available in three sizes. The coils are rated 6-250Vdc, 24-250Vac, and have a maximum stabilised wattage for the temperature classification and ambient temperature range for each size of solenoid as indicated below.

Solenoid size	Ambient temperature range	Maximum Power (W)		
		T4	T5	T6
2	-40°C to + 40°C	21.5	15.4	10.8
	-40°C to + 50°C	18.9	12.3	7.9
	-40°C to + 60°C	16.4	9.3	5.1
3	-40°C to + 40°C	22.2	16.4	11.4
	-40°C to + 50°C	19.5	13.0	8.4
	-40°C to + 60°C	16.8	9.9	5.5
4	-40°C to + 40°C	34.1	21.3	15.1
	-40°C to + 50°C	29.8	17.1	11.1
	-40°C to + 60°C	25.6	13.1	7.3

CONDITIONS OF CERTIFICATION: YES as shown below:

1 The solenoid must only be used on valve sizes with heat dissipation specified by the manufacturer of the solenoid in the instructions. The solenoid must be completely assembled with the valve before the solenoid is energised.

2 The solenoid and the valve on which it is mounted must not be thermally lagged.

3 The fluid flowing through the valve must not exceed the specified ambient temperature.

4 The solenoid shall be protected by a fuse rated for a prospective short circuit current of at least 1500A.



Issued: 16th May 2014
Page 1 of 1

Schedule to ATEX Quality Assurance Notification / IECEx Quality Assessment Report
Number: 3558
Issued to: Lisk Ireland Ltd

Products for which the company manufactures the product, but for which the following company controls the design: G.W. Lisk Company Inc - 0435		
Product Type Designation	Type Examination Certificate Number (Including ATEX)	IECEx Certificate of Conformity Number
Product category - Ex me		
The Type D/K XX-XD-XD Solenoids	Baseefa02ATEX0199X	IECEx BAS 13.0093X

Cert - Qaschedule - Issue 7 - February 2008

A4. Declaration of conformity - Solenoid



LISK IRELAND LIMITED



Ennis Road, Gort, Co. Galway, Ireland. Telephone: (353) 91-631711, 631101 Fax: (353) 91-633011

MANUFACTURERS STATEMENT

In Relation to:

INGRESS PROTECTION (IP) RATING OF



SOLENOIDS RATED FOR USE IN HAZARDOUS LOCATIONS

SOLENOIDS OF THE FOLLOWING DESIGNATION ARE CERTIFIED TO

HAVE AN

INGRESS PROTECTION RATING OF

IP66 in accordance with BS5490

D10-****D-*, D12-****D-*, D14-****D-*, D15-****D-*,
D16-****D-*, D19-****D-*,
&
K10-****D-*, K12-****D-*, K14-****D-*, K15-****D-*,
K16-****D-*, K19-****D-*,

Engineering Manager.

March 2010.

A5. Mounting instruction cable gland

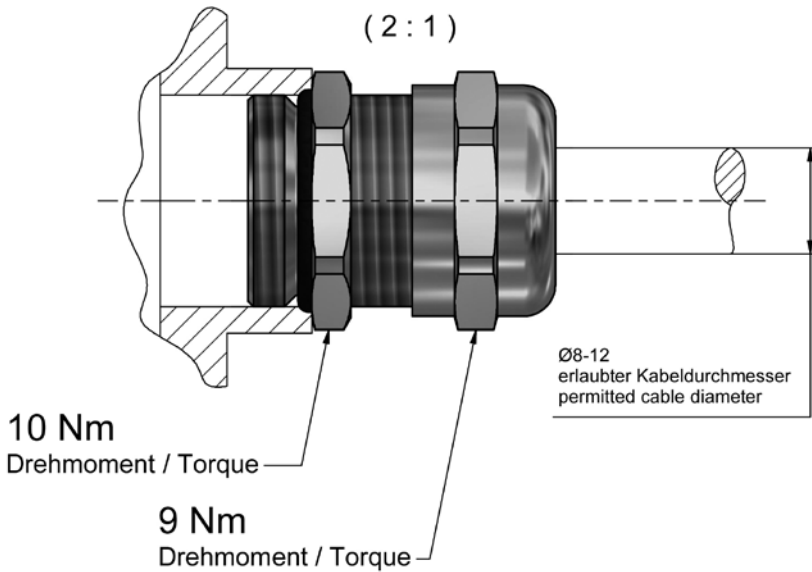

Der Nutzer muss beim elektrischen Anschließen des Ventils sicherstellen, dass die oben aufgeführten Drehmomente eingehalten werden.
Auslieferungszustand der Kabeldurchführung:
entweder am Ventil handfest eingeschraubt oder in Tüte beigelegt.

When connecting the valve electrically, the user must ensure that the torques listed above are observed.
Delivery condition of the cable entry:
either screwed hand-tight on the valve or enclosed in a bag.

Supersedes drawing		Material		Raw part		Change-Nr. 06-FEB-2020_TT	
ISO/R 128 A		Property of PARKER HANNIFIN				Prod. Stat: PR= Series Release EX = Prototype; No Series Release	
		Not to be used; disclosed; or copied without its written consent. To be returned with all copies upon completion of authorized use.					
		Originator Broeckmann		Date 24.08.2010			
Geometrical tolerancing acc. to DIN ISO 1101		1st. Approver Tschetschko		Date 24.08.2010		Parker Hannifin Industrial Systems Division Europe Gutenbergstr. 38 41564 Kaarst (Germany)	
Surface finish acc. to DIN ISO 1302		Scale 2:1		Units mm			
General tolerance acc. to DIN ISO 2768-m K		Title ATEX Kabelverschraubung					
Nominal size range (mm)	0,5 to 6	>6 to 30	>30 to 120	>120 to 400	>400 to 1000	>1000 to 2000	
Tolerance	±0,1	±0,2	±0,3	±0,5	±0,8	±1,2	
Sheet	1 / 2	Size	A4	Drawing number		5005113	
Rev.	B	Prod. Stat.	PR				

